

Series 09SVP-03

Single Axis Valve Gate Nozzle

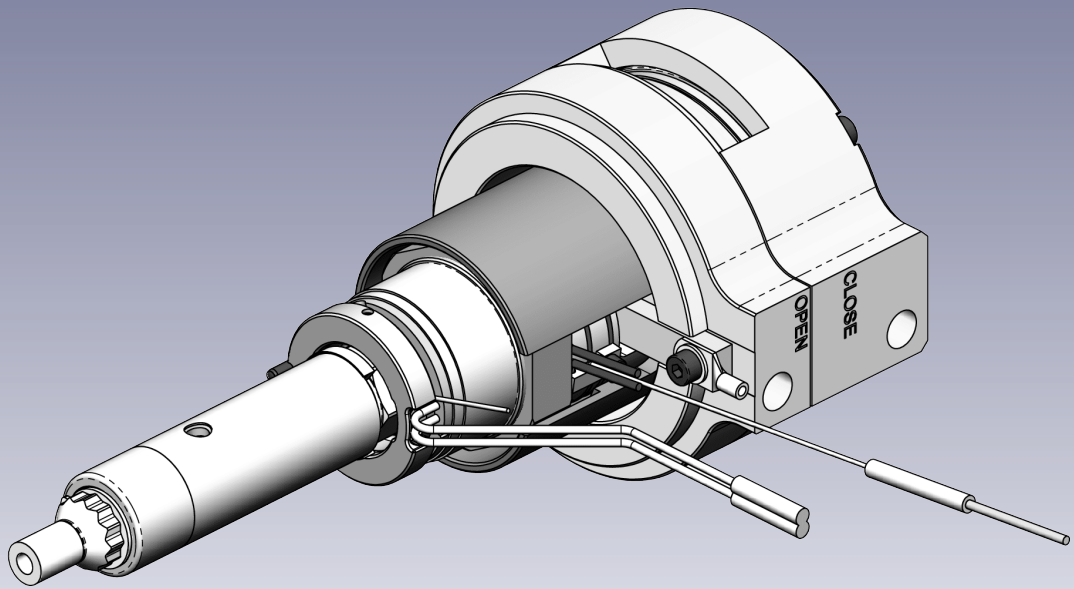

Doc009116_RIS.png

Stabilize your Process _____

CAT-01-0106_EN-Rev01 (EN) 02 / 2023



Product Description - Technical Data

Illustrations simplified, schematically drawn and not to scale. All dimensions in mm.

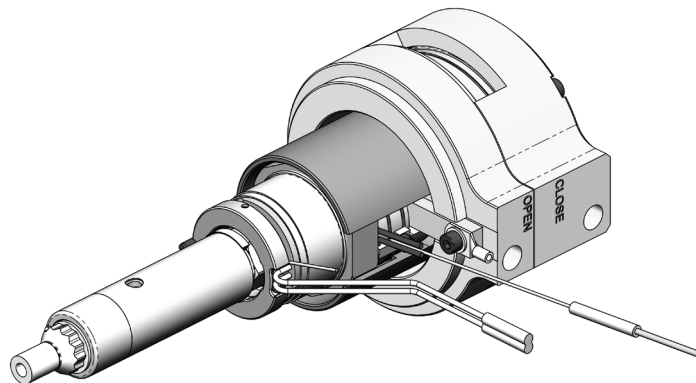

Doc009116_RIS_01.png

Valve Pin Operation	
Operation medium	pneumatic
Pressure range	5 - 10 bar (72.5 - 145 psi)
Flowrate	1.2 l/min / 5 bar (72.5 psi)
Reaction time	~1,2 s
Valve pin stroke:	8 mm
Adjustment	± 1.5 mm Via adjustment threads from outside.
Closing force	792 N / 6 bar (87 psi)
Opening force	792 N / 6 bar (87 psi)
Connection	M10x1 (8-L)
Valve pin	
Valve pin diameter	Ø 3,8 mm
Attachment	Quick coupling, anti-rotation
Cooling	
	Without being directly cooled the single axis valve gate nozzles 09SVP-03 can be used up to a mold temperature of 80 °C (176 °F).
Heating Power	
externally heated, 230 V AC	The numbering of the heating zones starts at the nozzle tip and ends at the nozzle head.
Zone 1 (From a nozzle length of 50-<170 mm)	150 - 260 Watt
Zone 2 (From a nozzle length of 170-390 mm)	130-360 Watt
Head	450 plus 500 Watt
Thermocouple	
EN 60584 Fe-CuNi 0 = Typ J; NiCr-Ni = Typ K	
The heater & thermocouple are replaceable.	
Application	
For all usual thermoplastics Max. shot weight per nozzle (g): → 80 (low viscosity)	

NOTICE

To ensure long life and continued flawless operation of the actuator, we recommend using filtered compressed air.



09SVP-03 Single Axis Valve Gate Nozzle, pneumatic

Product Description - Dimensions - Heater Zones Power

Illustrations simplified, schematically drawn and not to scale. All dimensions in mm.

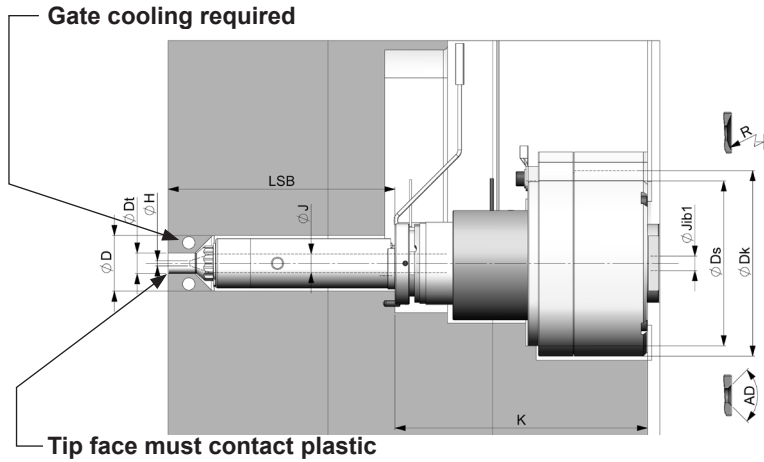

Doc009117_RIS.png

J	Flow bore	Ø 09 ¹⁾	H	Gate orifice	see page 7
Jib1	Flow bore inlet bushing	Ø 7	K	Head height	122,5
LSB	Nozzle length	50...400 ²⁾	Dk	Head diameter	Ø 90
F	Tip extension	see page 7	Ds	Diameter of head centering	Ø 80
D	Cutout	Ø 27	R	Nozzle contact radius	0...40
Dt	Tip Ø	see page 7	AD	Nozzle contact angle	90°...120°

1) Standard flow bore value = Ø 9
consult Synventive for custom dimensions Ø 7, Ø 8, Ø 10
2) Standard lengths shown, consult Synventive for custom lengths.

One control area (thermocouple)			Two control areas (thermocouple)				Adapter Head	Head Bot-tom
LSB (mm)		Heater zone power (Watt)	LSB (mm)		Heater zone power ¹⁾ (Watt)			
Standard lengths	Custom lengths	Power1	Standard lengths	Custom lengths	Power 1	Power 2	Power	Power
50	>50-<60	150 W	-	=>160-<170	150 W	130 W	450 W	500 W
60	>60-<70	180 W	170	>170-<180	150 W	140 W	450 W	500 W
70	>70-<80	210 W	-	=>180-<190	150 W	150 W	450 W	500 W
80	>80-<90	215 W	190	>190-<200	150 W	160 W	450 W	500 W
90	>90-<100	220 W	-	=>200-<210	150 W	170 W	450 W	500 W
100	>100-<110	225 W	210	>210-<220	150 W	180 W	450 W	500 W
110	>110-<120	230 W	-	=>220-<230	150 W	190 W	450 W	500 W
120	>120-<130	235 W	230	>230-<240	150 W	200 W	450 W	500 W
130	>130-<140	250 W	-	=>240-<250	150 W	210 W	450 W	500 W
-	=>140-<150	255 W	250	>250 -<260	150 W	220 W	450 W	500 W
150	>150-<160	260 W	-	=>260 -<270	150 W	230 W	450 W	500 W
			270	>270-<280	150 W	240 W	450 W	500 W
			-	=>280-<290	150 W	250 W	450 W	500 W
			290	>290-<300	150 W	260 W	450 W	500 W
			-	=>300-<310	150 W	270 W	450 W	500 W
			310	>310-<320	150 W	280 W	450 W	500 W
			-	=>320-<330	150 W	290 W	450 W	500 W
			330	>330-<340	150 W	300 W	450 W	500 W
			-	=>340-<350	150 W	310 W	450 W	500 W
			350	>350-<360	150 W	320 W	450 W	500 W
			-	=>360-<370	150 W	330 W	450 W	500 W
			370	>370-<380	150 W	340 W	450 W	500 W
			-	=>380-<390	150 W	350 W	450 W	500 W
			390	-	150 W	360 W	450 W	500 W

³⁾ The numbering of the heating zones starts at the nozzle tip and ends at the nozzle head



Cutout in Mold Plate for Nozzle and Connections

Illustrations simplified, schematically drawn and not to scale. All dimensions in mm.

Cutout for the Nozzle

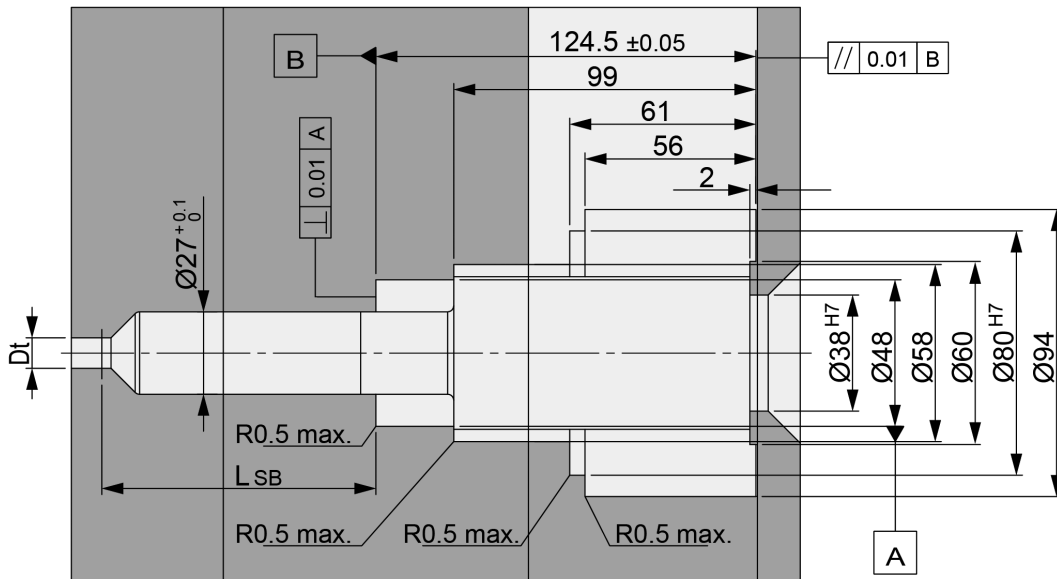

Doc007335.png

Cutout for Connections (Electrical power and Thermocouple)

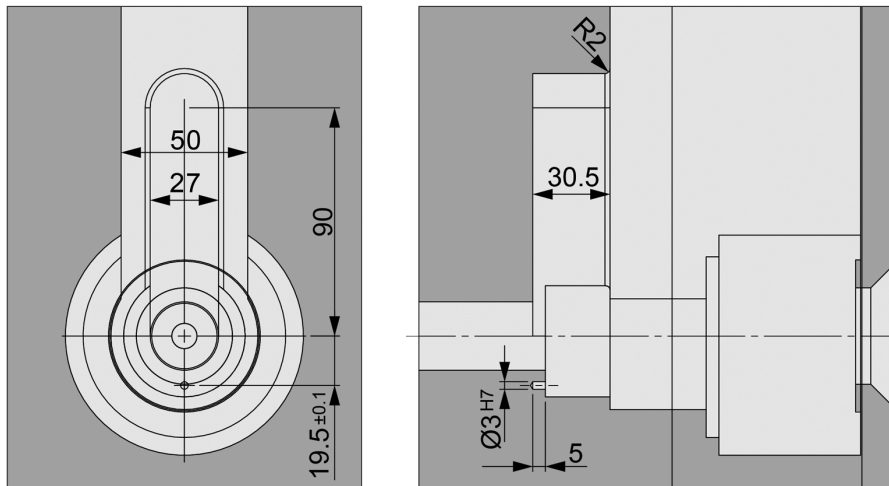

Doc007336.png

General tolerances: DIN ISO 2768-mK

Surfaces: $\sqrt{Ra 3.2}$ ($\sqrt{Ra 1.6}$ $\sqrt{Ra 0.8}$)

Values of the dimension LSB can be found in the data sheet on page 3.



Product Description - Cooling Unit CU07SVP01

Illustrations simplified, schematically drawn and not to scale. All dimensions in mm.

**CU07SVP01 mounted on
Single Axis Valve Gate Nozzle
09SVP-03**

CU07SVP01 Technical Data	
Medium	Cooling water
Flow rate	4 l/min
Pressure	max. 8 bar (116 psi)
Temperature	30...60 °C (86 - 140 °F)
Connections	M14x1.5

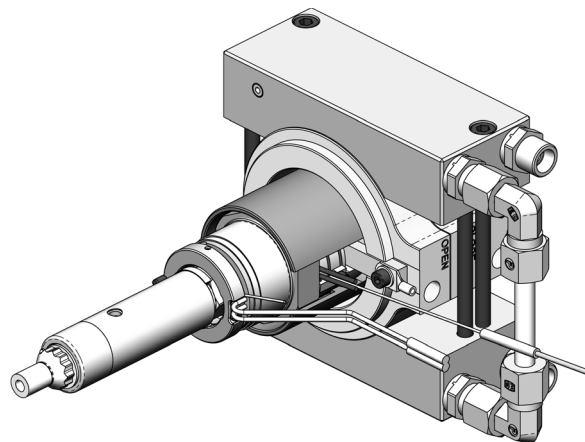

Doc009128_RIS.png

Parts List

Pos.	Qty.	Description/ Part Number
01	2	Cooling Sleeve / CU07SVPCS01
02	1	Connecting Tube / CU07SVPCT01
03	2	Sealing Plug / Z942/6
04	4	Straight Coupling / GE08LMEDVITOMDCF
05	2	Elbow Coupling / EW08LVITOMDCF
06	2	Cutting Ring / PSR08LX
07	2	Nut / M08LCFX
08	3	Hexagon Socket Cap Screw / DIN912-M6x95-12.9

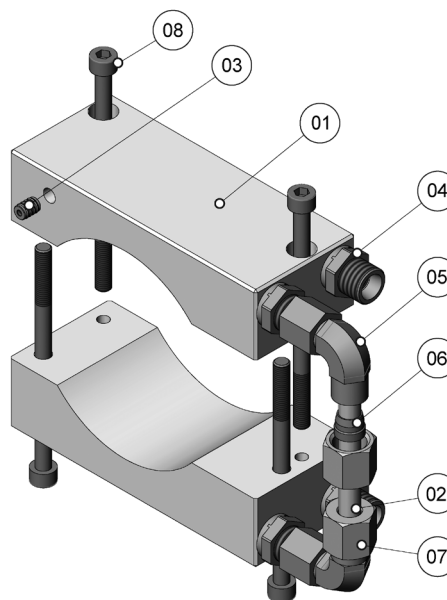

Doc005051.png

**Position of the cooling unit on
the Single Axis Valve Gate
Nozzle 09SVP-03**

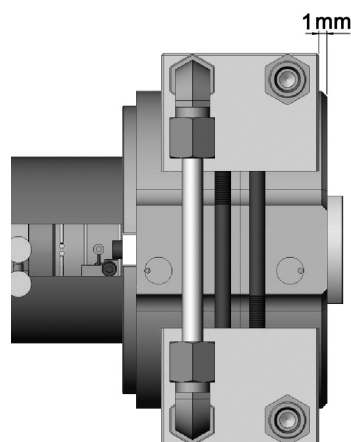

Doc005052.png



09SVP-03 Single Axis Valve Gate Nozzle, pneumatic

Cutout in Mold Plate for Nozzle with Cooling Unit CU07SVP01

Illustrations simplified, schematically drawn and not to scale. All dimensions in mm.

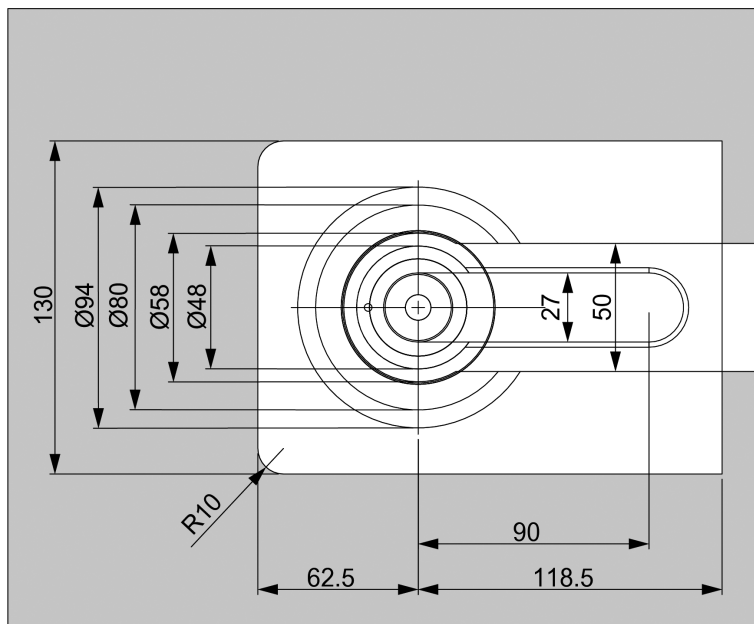
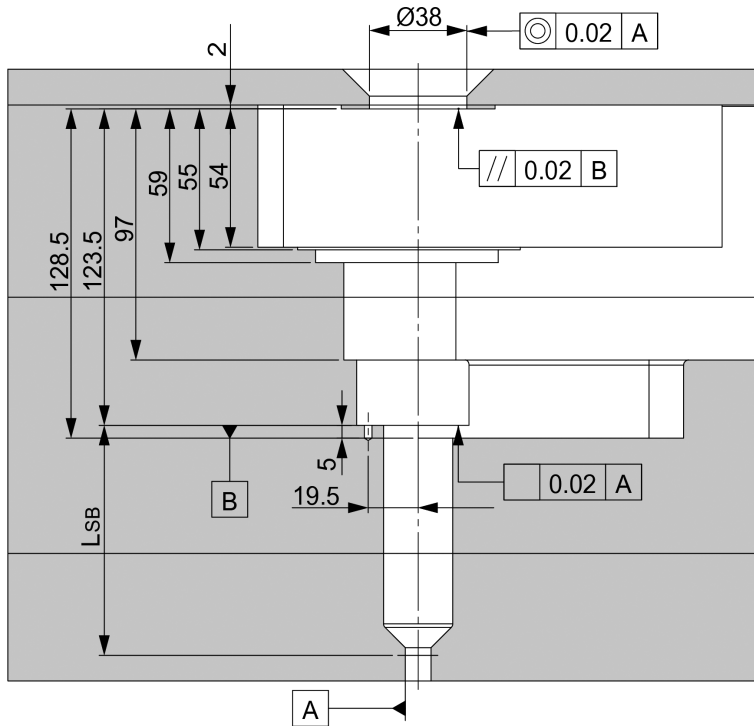

General tolerances: DIN ISO 2768-mK

Doc007388.png

Surfaces: $\sqrt{Ra\ 3.2}$ ($\sqrt{Ra\ 1.6}$ $\sqrt{Ra\ 0.8}$)

Values of the dimension LSB can be found in the data sheet on page 3.



Nozzle Tip Styles

Illustrations simplified, schematically drawn and not to scale. All dimensions in mm
 H = Gate orifice diameter, F = Tip extension, Dt = Tip Diameter, Mod = Modifiable

VSP Valve Gate - Straight Pin - Plunged Through

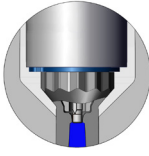
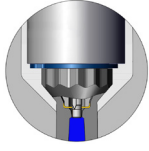
Tip Style		Description	Application range	Dt = Ø10 F = 0, 10, Mod H=2.5			
	VSP Doc009082_RIS.png			Universal	for all common plastics	✓	
		Seal cap	for color change	✓			

VSW Valve Gate - Straight Pin - Blind

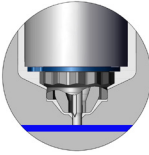
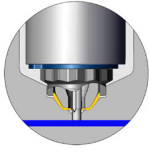
Tip Style		Description	Application range	Dt = Ø14			
				H=1.5	H=2.0	H=2.5	H=3.0
	VSW Doc009084_RIS.png	Universal	for all common plastics	✓			
		Seal cap	for color change	✓			

✓ Preferred

(✓) Available

✗ Not Available



Nozzle Tip Cutout Dimensions

Illustrations simplified, schematically drawn and not to scale. All dimensions in mm.
Dimensions for reference only. Reference system drawing for complete dimensions prior to machining gate detail in mold.

VSW - Nozzle tip cutout dimensions

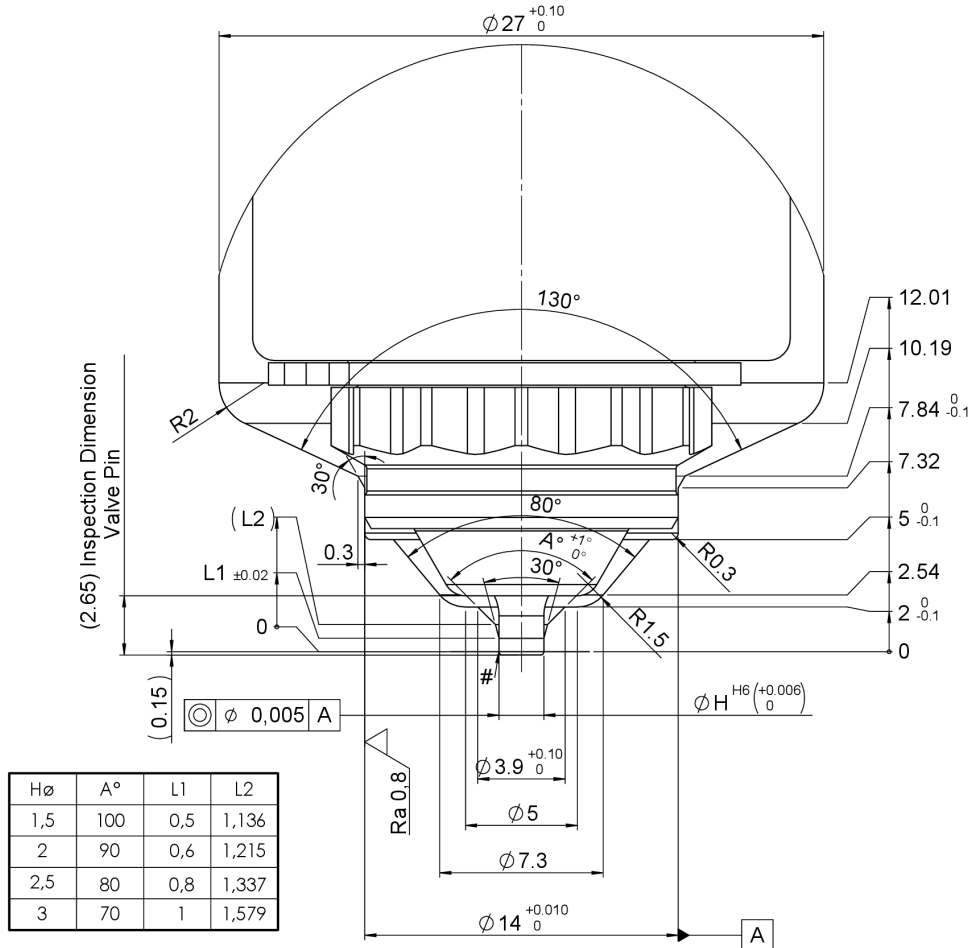

Doc009118_RIS.png

Notes:

- Cooling required around the nozzle tip, opposite to the nozzle tip
- The front of the nozzle tip must always be against plastic.

General tolerances according to DIN ISO 2768-mK

1. At the area of the nozzle gate replaceable, hardened (52 +2/-1 HRC) inserts are recommended by Synventive.
2. Radius / chamfer at the front of the valve pin shall not be removed.
3. Synventive recommends that the gate area geometry is manufactured by grinding and not EDM with a surface quality of $\sqrt{Ra 0.8}$.
4. To avoid a deformation at the gate the space to move freely has to be checked at hot condition.
5. For angled surface the valve pin may not be adjusted toward cavity.
6. Ensure 0.5 mm sealing surface is maintained.

The Americas

Synventive Molding Solutions Inc.
10 Centennial Drive
Peabody, MA 01960
Tel.: +1 978 750 8065
Fax: +1 978 646 3600
Email: info@synventive.com

Europe

Synventive Molding Solutions GmbH
Heimrodstraße 10
P. O. Box 3123
64625 Bensheim
Tel. :+49 (0)6251 9332-0
Fax :+49 (0)6251 9332-90
Email: infohrde@synventive.com

Asia

Synventive Molding Solutions (Suzhou) Co. Ltd.
12B Gang Tian Industrial Square
Suzhou Industrial Park, China 215021
Tel.: +86 512 6283 8870
Fax: +86 512 6283 8890
Email: infohrcn@synventive.com

 **Synventive**[®]
molding solutions



A business of BARNES