

# Hot Sprue Bushings

## Products/Technical Guide



# USB5 AND SB5 HOT SPRUE BUSHINGS

## Notes

1. Cold bushing length must allow for thermal expansion to fit specified mold length.
2. For special "A" length, order next longer model and specify exact length required (e.g., special "A" = 2.556; order model USB5-2020).
3. For use with 3-plate molds, machine a stripper plate sleeve (see Technical Guide "Section F") in conjunction with a standard model bushing using CV-10 or CV-11 tip style.
4. When tip extension is specified, mold length "A" does not change, but is provided at same nominal length for the given size bushing. Overall length ("OAL" on drawing) is the affected dimension.
5. 420 SS bushings are available on special order for processing PVC or other corrosive materials.

### USB5

.750 Mold/Tip Diameter  
.197 Flow Bore Diameter

### SB5

19mm Mold/Tip Diameter  
5mm Flow Bore Diameter

## Ideal for Smaller Injection Molds

Synventive USB5 and SB5 hot sprue bushings are available in standard mold lengths ("A" dimension on drawing) to exactly match standard mold plate thickness. The .750 (19mm) diameter tip allows the bushings to be a direct replacement for all conventional .750 (19mm) cold sprue bushings, in U.S.A. standard molds.

All bushings come complete with replaceable hard radius seat, mineral insulated heater band and thermocouple hole. A 0.500 or 0.750 inch spherical radius is standard. Metric radii are provided upon specification.

## Specifications

Max. Operating Pressure: 20,000 psi (1400 bar)

Max. Operating Temperature: 650°F (345°C)

Mode of Operation - Horizontal

Heater: 45mm (1.75) I.D. x 35mm (1.38) wide,  
450 W, 120 or 240 V

Heater Clearance Diameter: 85mm (3.25)

	USB5	SB5
"A" min.	.875	22
"A" max.	4.375	106
"D1"	.750	19h6
"D2"	2.000	50
"D3"	1.750	45
"D4"	.197	5.00
"T"	.875	26
"R"	To Suit	To Suit
"L1"	.531	13.5
"L2"	.157	4
"G"	.020	.50

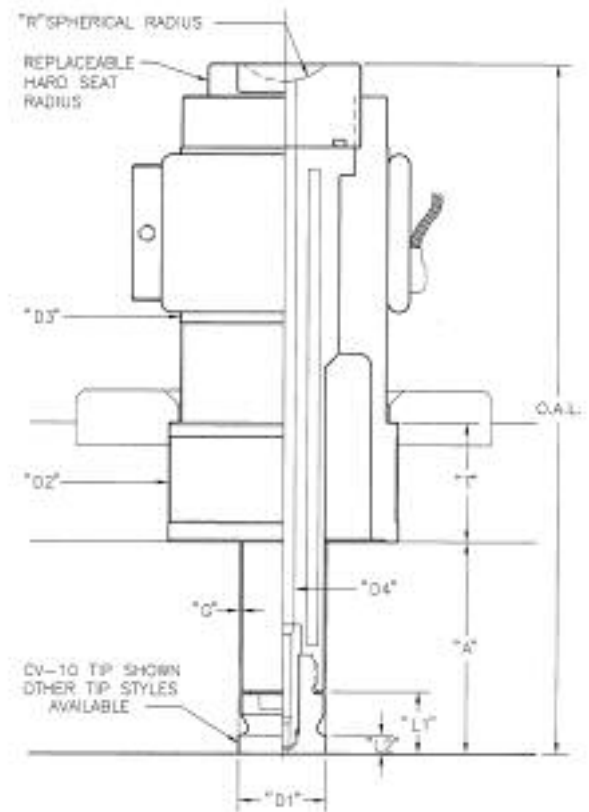

# ORDERING INFORMATION – See Worksheet Page 19

## To Order:

1. Choose bushing based on mold depth ("A" dimension on drawing).

Model	Maximum "A" Dimension	Cold Bushing Length	OAL
USB5-0020	.875	.872	4.98
USB5-1010	1.375	1.371	5.37
USB5-1020	1.875	1.869	5.77
USB5-2010	2.375	2.368	6.16
USB5-2020	2.875	2.866	6.56
USB5-3010	3.375	3.365	7.34
USB5-3020	3.875	3.863	7.74
USB5-4010	4.375	4.362	8.13

Model	Maximum "A" Dimension	Cold Bushing Length	OAL
SB5-022	22mm	21.93mm	126mm
SB5-027	27mm	26.92mm	136mm
SB5-036	36mm	35.89mm	146mm
SB5-046	46mm	45.86mm	156mm
SB5-056	56mm	55.83mm	166mm
SB5-066	66mm	65.80mm	176mm
SB5-076	76mm	75.77mm	186mm
SB5-086	86mm	85.74mm	196mm
SB5-096	96mm	95.71mm	206mm
SB5-106	106mm	105.68mm	216mm

2. Specify desired tip style based on material/ vestige height considerations (see p. 6 for tip descriptions)

3. Specify additional required information (based on tip style).

- a. USB5 and SB5 bushings are not recommended for glass filled materials. Use USB8 and SB8 bushing with abrasion resistant inserts
- b. CV-10 tip has multiple insert orifice diameters. For optimum gate control, it is necessary to specify the required orifice diameter or specify the material, shot size and fill time for Synventive to determine what orifice diameter will best suit the application.
- c. CV-11 tip requires that the exact tip orifice be specified on the order.
- d. Specify 420 SS bushing if required.
- e. See Technical Guide "Section A" for tip reduction/modification instructions.

Tip Style	Description
CV-10	Gate/Full Flow
CV-11	Gate/Cone
CV-20	Open/Full Flow
CV-21	Open/Cone

Tip Style	Spherical Radius	Tip Extension	Tip Runner Radius	Tip Orifice
	.500 or .750 (12.7 or 19mm)	0-.312 (8mm)	0-.187 (0-4.7mm)	
CV-10	Yes	Yes	Yes	No <sup>b</sup>
CV-11	Yes	Yes	Yes	Yes <sup>c</sup>
CV-20	Yes	No	Yes	No
CV-21	Yes	No	No	No

## USB5 Cad Library Drawings

Tip Style	Drawing
CV-10	USB5CV10 (section)
CV-11	USB5CV11 (section)
CV-20	USB5CV20 (section)
CV-21	USB5CV21 (section)

## Nozzle Style

USB5-0022	Drawing
USB5-1010	US50022S (section) US5T (top)
USB5-1020	US51010S (section) US5T (top)
USB5-2010	US51020S (section) US5T (top)
USB5-2020	US52010S (section) US5T (top)
USB5-3010	US52020S (section) US5T (top)
USB5-3020	US53010S (section) US5T (top)
USB5-4010	US53020S (section) US5T (top)
	US54010S (section) US5T (top)

## SB5 Cad Library Drawings

Tip Style	Drawing
CV-10	SB5CV10 (section)
CV-11	SB5CV11 (section)
CV-20	SB5CV20 (section)
CV-21	SB5CV21 (section)

## Nozzle Style

SB5-022	Drawing
SB5-027	SB5022S (section) SB5T (top)
SB5-036	SB5027S (section) SB5T (top)
SB5-046	SB5036S (section) SB5T (top)
SB5-056	SB5046S (section) SB5T (top)
SB5-066	SB5056S (section) SB5T (top)
SB5-076	SB5066S (section) SB5T (top)
SB5-086	SB5076S (section) SB5T (top)
SB5-096	SB5086S (section) SB5T (top)
SB5-106	SB5096S (section) SB5T (top)
	SB5106S (section) SB5T (top)

## "A" Dimension (Mold Depth)

When tip extension is specified, mold length "A" does not change, but is provided at the same nominal length for the given size bushing. Overall length ("OAL" on drawing) is the affected dimension.

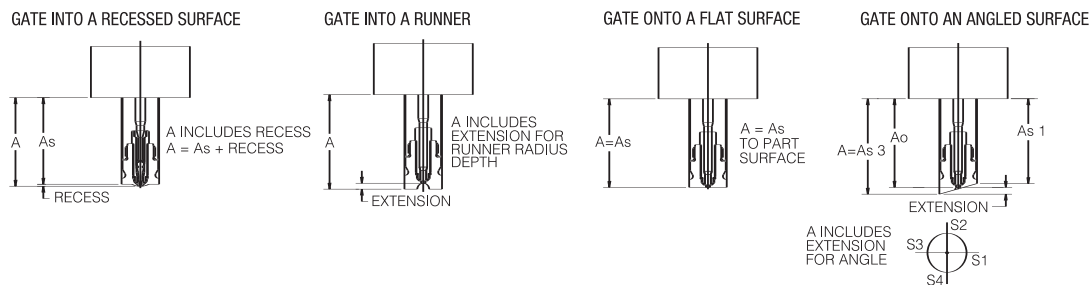

When gating into a runner, CV-20 or -21 tip styles are recommended. If using a CV-10 or CV-11 tip, tip should be "moved back" 0.25mm (.010) hot from parting line, so a thin wafer is molded.

### SB/USB5&8 SBP/USBP8 Hot Sprue Bushing Worksheet

This worksheet needs to be filled out completely. Information not applicable, please fill in N/A.

#### Customer Information

Company: \_\_\_\_\_  
 Address: \_\_\_\_\_  
 End User: \_\_\_\_\_

Contact: \_\_\_\_\_  
 Tel: \_\_\_\_\_  
 Fax: \_\_\_\_\_  
 Email: \_\_\_\_\_  
 Job #: \_\_\_\_\_  
 PO#: \_\_\_\_\_

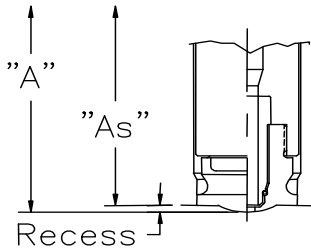
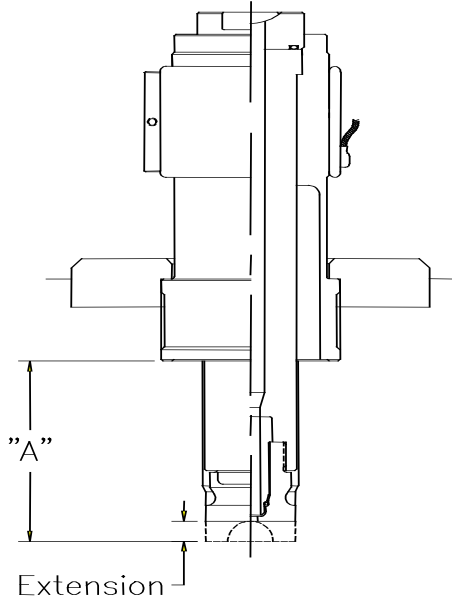

Gating into a recessed surface

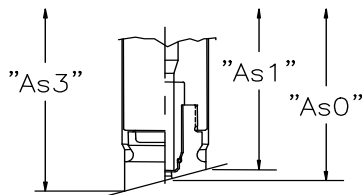

Gating onto an angled surface

**Bushing Style:**  SB5  SBP8 (Tip Heated)  
 USB5  USBP8 (Tip Heated)  
 SB8  
 USB8

**Tip Style:**  CV-10  CV-20  
 CV-11  CV-21

Mold "A" Length "A": \_\_\_\_\_  
 Tip Extension: \_\_\_\_\_  
 (If no extension is required, specify "0")

Tip Orifice Diameter: \_\_\_\_\_

**Molding Material:**  
 Manufacture/Grade: \_\_\_\_\_  
 Filler:  None  Glass  Other:  
 \_\_\_\_\_ % of Filler

Flame Retardant:  No  Yes  
 Part Weight: \_\_\_\_\_ or Shot Size : \_\_\_\_\_  
 Number of Cavities: \_\_\_\_\_

**Part; Average Wall Thickness:**  
 Runner:  No  Yes, Runner Diameter: \_\_\_\_\_  
 Recess:  No  Yes, Recess Depth: \_\_\_\_\_  
 Angled Surface:  No  Yes "AsO": \_\_\_\_\_  
 "As1": \_\_\_\_\_  
 "As3": \_\_\_\_\_

Gating Opposite Cosmetic Surface:  No  Yes  
 Color Change:  No  Yes

Spherical Radius: (mates with machine nozzle tip)  
 12.7 [.500]  19.05 [.750]  Other: \_\_\_\_\_

Voltage:  120  240

Special Requirements (if any): \_\_\_\_\_  
 \_\_\_\_\_

# BUSHING CAVITY REQUIREMENTS BY TIP STYLE

## Notes

Gate Full Flow CV-10

Gate Orifice

1.5 – 2.3

(.059" – .091")

### USB5 Bushing (inches)

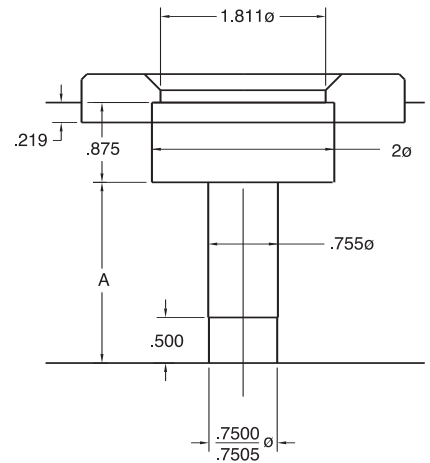
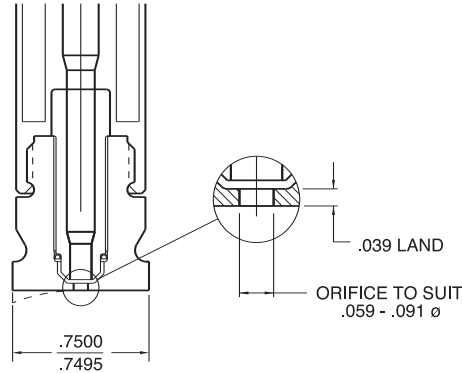

Gate Cone CV-11

Gate Orifice

0.9 – 2.2

(.035" – .087")

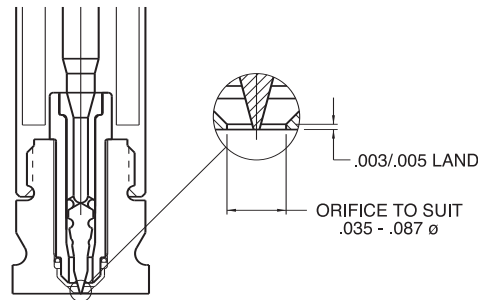

Open Full Flow CV-20

Gate Orifice

1.5 – 2.3

(.059" – .091")

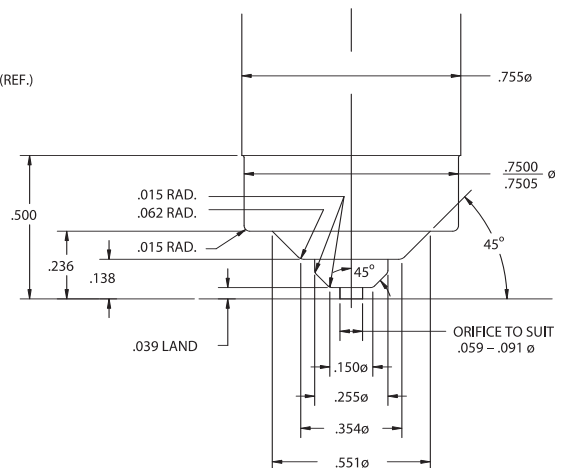
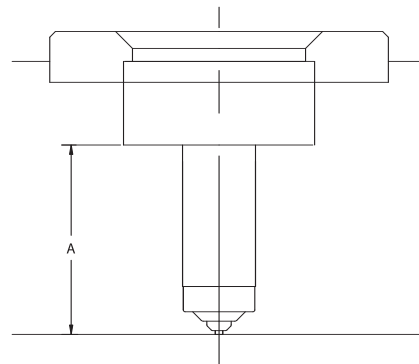
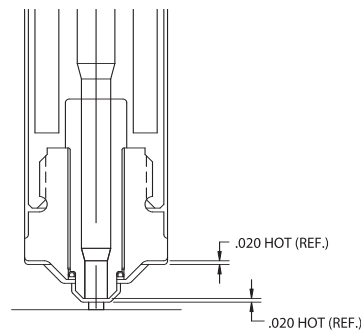

**SB5 Bushing (metric)**

**Notes**

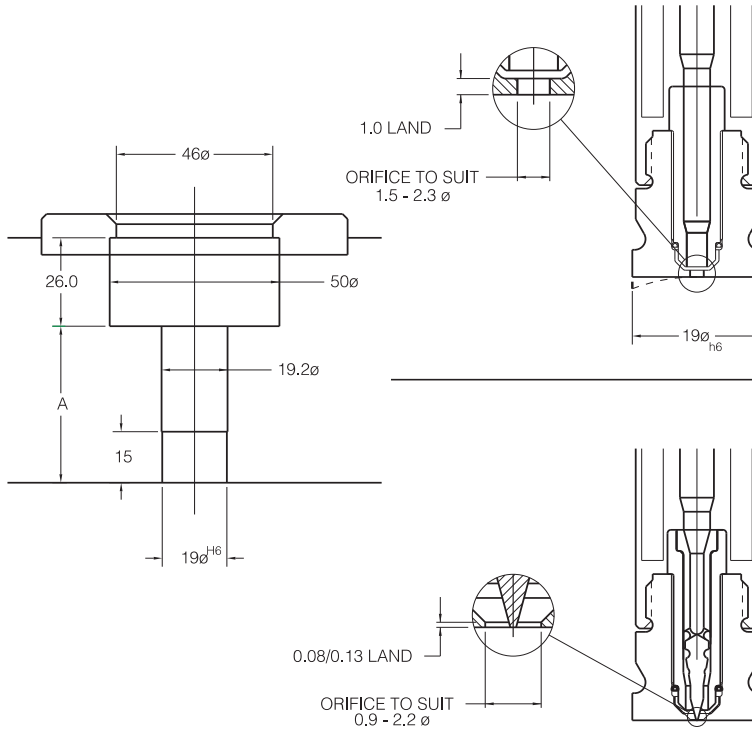

Gate Full Flow CV-10

Gate Orifice  
1.5 – 2.3  
(.059" – .091")

Gate Cone CV-11

Gate Orifice  
0.9 – 2.2  
(.035" – .087")

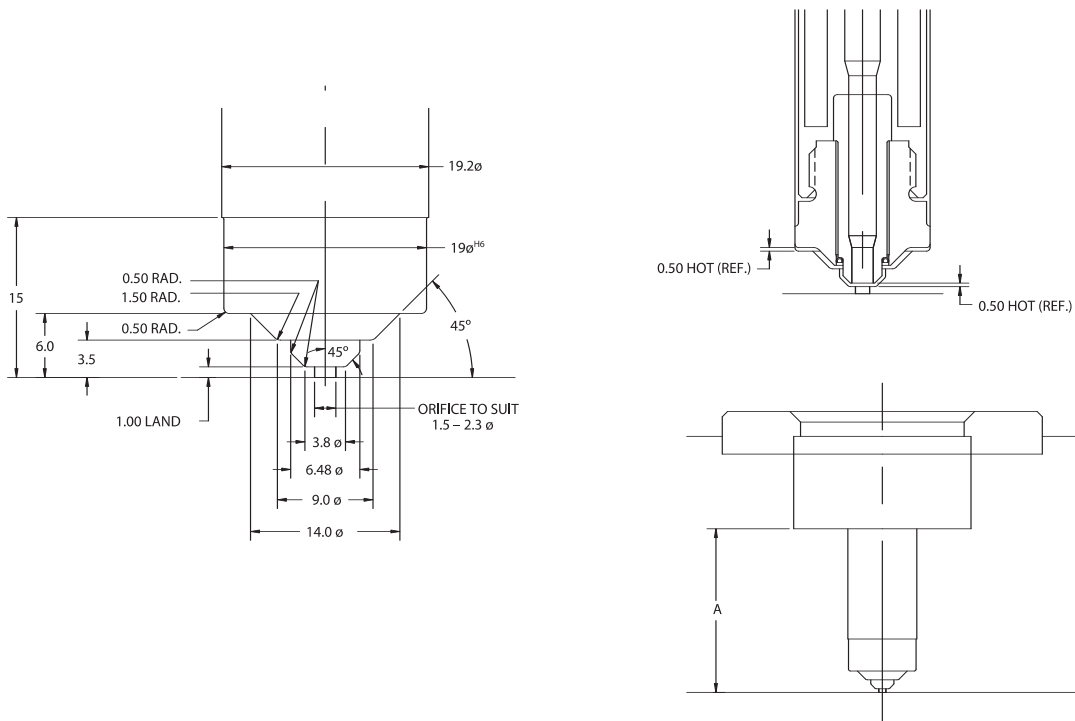

Open Full Flow CV-20

Gate Orifice  
1.5 – 2.3  
(.059" – .091")

# BUSHING CAVITY REQUIREMENTS BY TIP STYLE

## Notes

Open Cone CV-21

Gate Orifice

0.9 – 2.2

(.035" – .087")

### USB5 Hot Sprue Bushing (inches)

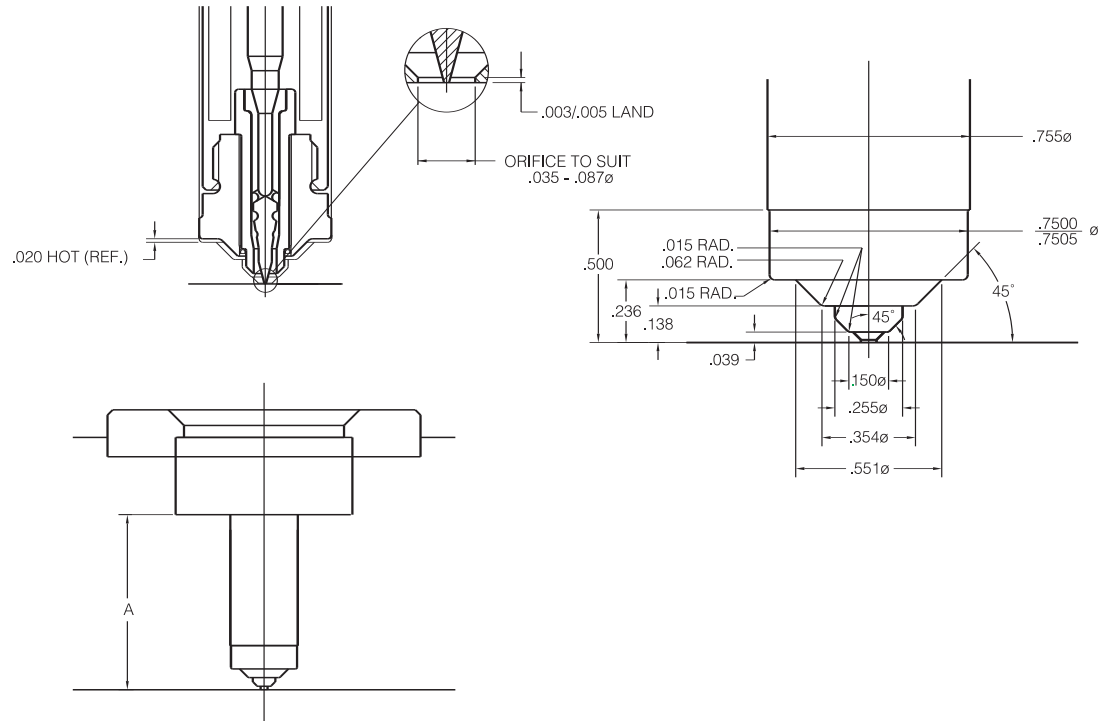

### SB5 Hot Sprue Bushing (metric)

Open Cone CV-21

Gate Orifice

0.9 – 2.2

(.035" – .087")

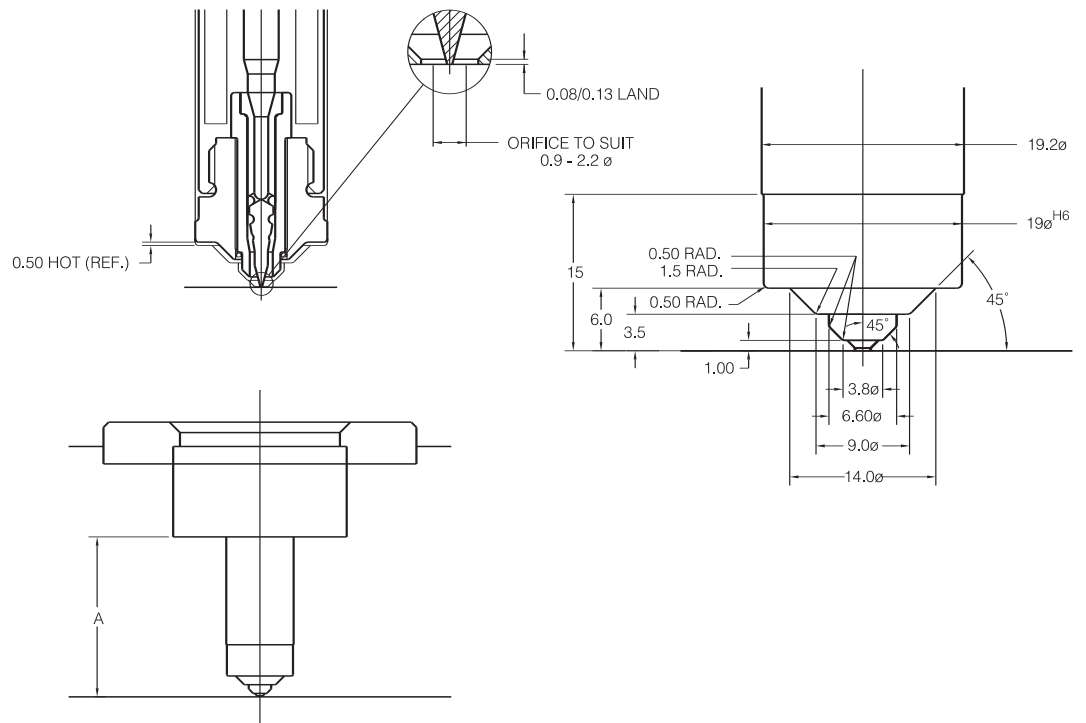

**SB5 Hot Sprue Bushing (metric) With CV-10 Tip**

SPHERICAL GATE RECESS

CONICAL GATE RECESS

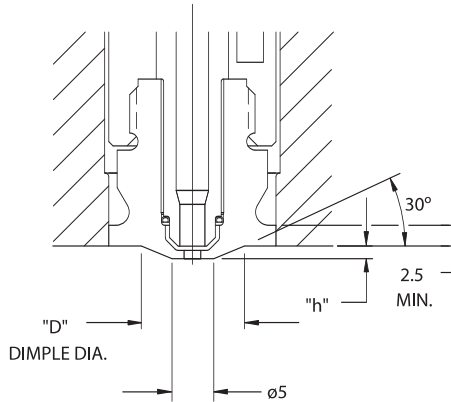
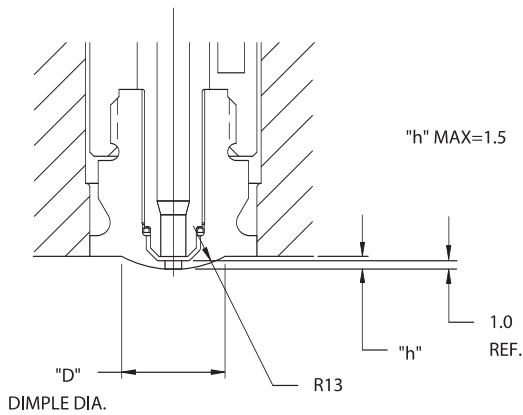

NOTE:  
FOR MOST MATERIALS, CV-10 VESTIGE HEIGHT IS EQUAL TO (1.0mm + ORIF./2). IF VESTIGE HEIGHT RELATIVE TO THE POSSIBLE GATE RECESS DEPTH IS TOO GREAT, USE OF A CV-11 TIP IS RECOMMENDED TO PRODUCE A SHORTER VESTIGE HEIGHT.

$$"D" = 2\sqrt{"h"(26 - "h")}$$

TABLE 1	
RECESS "h"	"D"
0.6	7.8
0.7	8.4
0.8	9.0
0.9	9.5
1.1	10.5
1.3	11.3
1.5	12.1

$$"D" = 5 + 3.5"h"$$

TABLE 2	
RECESS "h"	"D"
0.6	7.1
0.7	7.5
0.8	7.8
0.9	8.2
1.1	8.9
1.3	9.6
1.5	10.3

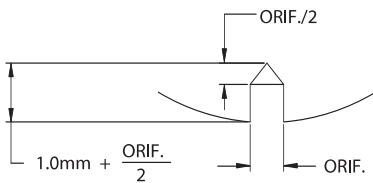

ANGLED MOLD CONTOUR

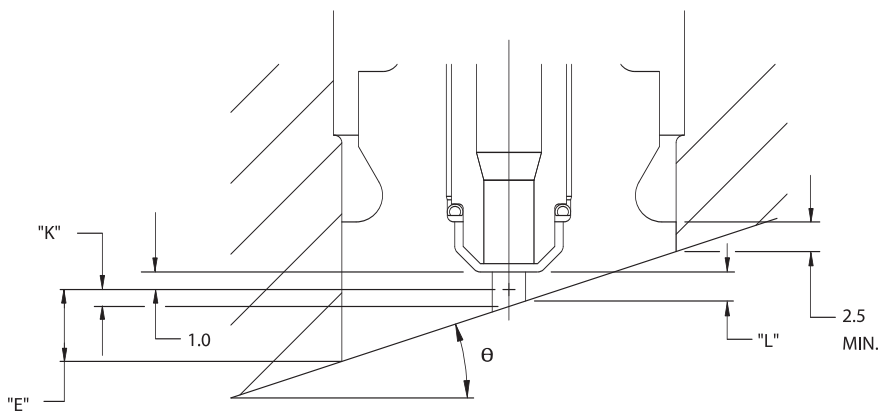

NOTE:

$$\theta \leq 9^\circ; "K" = 0$$

$$"E" = 9.5 \tan \theta$$

$$"L" = 1 - \left( \frac{\text{ORIFICE DIA.}}{2} \right) \tan \theta$$

$$\theta > 9^\circ; "K" = 9.5 \tan \theta - 1.5$$

$$"E" = 19 \tan \theta - 1.5$$

$$"L" = 1 + "K" - \left( \frac{\text{ORIFICE DIA.}}{2} \right) \tan \theta$$

"K" IS THE INCREASE IN ORIFICE LAND NECESSARY TO MAINTAIN 2.5 MINIMUM CONTACT.



# GATE MACHINING LIMITS FOR FIELD MODIFICATIONS

## USB5 Hot Sprue Bushing (inches) With CV-10 Tip

SPHERICAL GATE RECESS

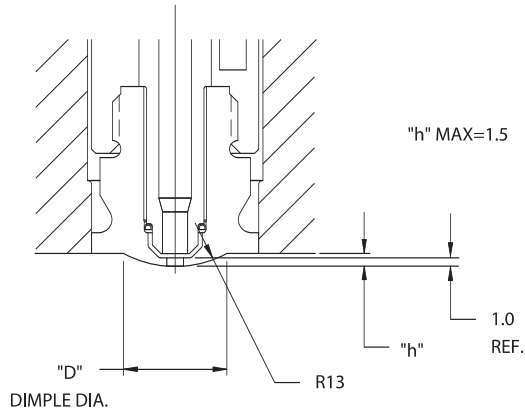

CONICAL GATE RECESS

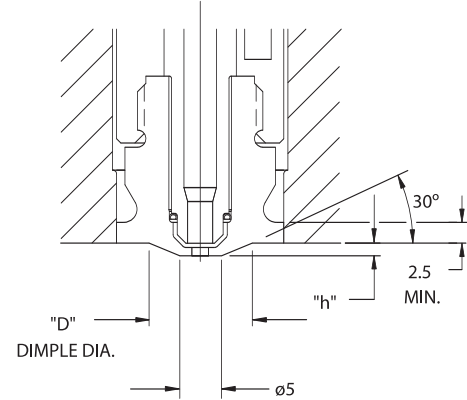

NOTE:

FOR MOST MATERIALS, CV-10 VESTIGE HEIGHT IS EQUAL TO (1.0mm + ORIF./2). IF VESTIGE HEIGHT RELATIVE TO THE POSSIBLE GATE RECESS DEPTH IS TOO GREAT, USE OF A CV-11 TIP IS RECOMMENDED TO PRODUCE A SHORTER VESTIGE HEIGHT.

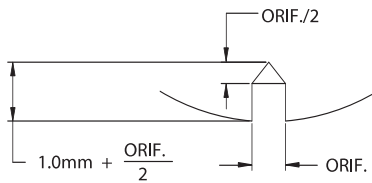

$$"D" = 2\sqrt{"h"(26 - "h")}$$

TABLE 1	
RECESS "h"	"D"
0.6	7.8
0.7	8.4
0.8	9.0
0.9	9.5
1.1	10.5
1.3	11.3
1.5	12.1

$$"D" = 5 + 3.5"h"$$

TABLE 2	
RECESS "h"	"D"
0.6	7.1
0.7	7.5
0.8	7.8
0.9	8.2
1.1	8.9
1.3	9.6
1.5	10.3

ANGLED MOLD CONTOUR

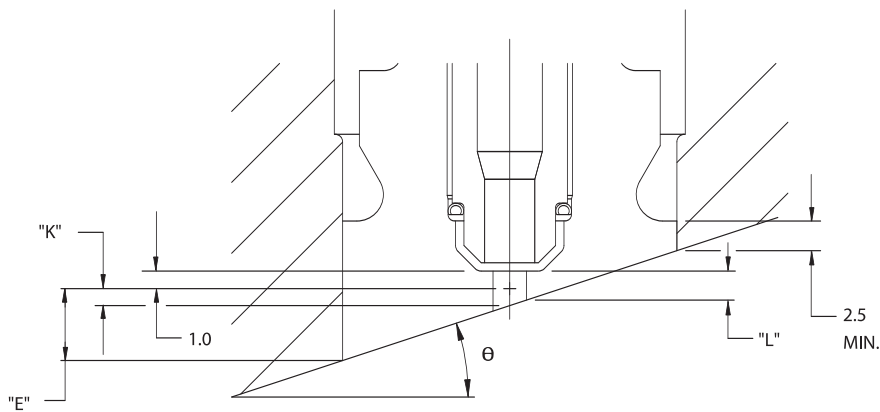

NOTE:

$$\theta \leq 9^\circ; "K" = 0$$

$$"E" = 9.5 \tan \theta$$

$$"L" = 1 - \left(\frac{\text{ORIFICE DIA.}}{2}\right) \tan \theta$$

$$\theta > 9^\circ; "K" = 9.5 \tan \theta - 1.5$$

$$"E" = 19 \tan \theta - 1.5$$

$$"L" = 1 + "K" - \left(\frac{\text{ORIFICE DIA.}}{2}\right) \tan \theta$$

"K" IS THE INCREASE IN ORIFICE LAND NECESSARY TO MAINTAIN 2.5 MINIMUM CONTACT.

# GATE MACHINING LIMITS FOR FIELD MODIFICATIONS

## Notes

Table 1&2 shows the recommended recess required to keep the vestige below the part surface. Consult Synventive when using glass fibers or other fillers.

## USB5 Hot Sprue Bushing (inches) With CV-11 Tip

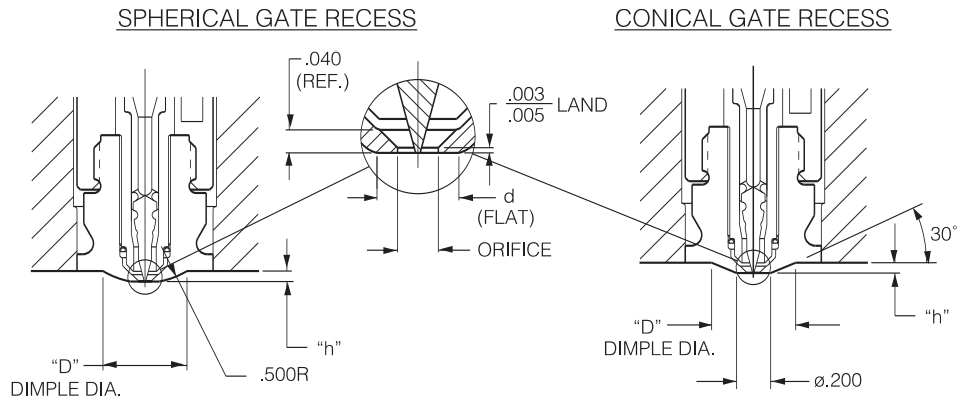

"h" MAX=.060

"D"=.200 + 3.5"h"

ORIFICE DIA.	RECESS h	d	D
.035-.039	.023	.049	.306
.039-.047	.026	.057	.327
.047-.055	.029	.065	.346
.055-.063	.031	.073	.361
.063-.071	.034	.081	.374
.071-.079	.037	.089	.392
.079-.087	.039	.096	.404

ORIFICE	RECESS "h"	"D"
.035	.022	.277
.039	.023	.281
.047	.026	.291
.059	.030	.305
.071	.034	.319
.079	.037	.330
.087	.039	.337

### ANGLED MOLD CONTOUR

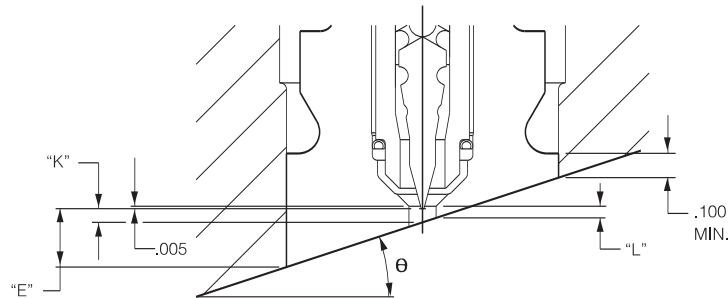

$$\theta \leq 15^\circ ; "K" = \left( \frac{\text{ORIFICE DIA.}}{2} \right) \text{TAN } \theta \quad \theta > 15^\circ ; "K" = \left( \frac{.715 - \text{ORIFICE DIA.}}{2} \right) \text{TAN } \theta - .100$$

$$"E" = \left( \frac{.075 + \text{ORIFICE DIA.}}{2} \right) \text{TAN } \theta \quad "E" = K + .375 \text{TAN } \theta$$

$$"L" = .005 \quad "L" = .005 + "K" - \left( \frac{\text{ORIFICE DIA.}}{2} \right) \text{TAN } \theta$$

NOTE:

K IS THE INCREASE IN ORIFICE LAND NECESSARY TO MAINTAIN .005 LAND AND/OR .100 MINIMUM CONTACT.

**SB5 Hot Sprue Bushing (metric) With CV-11 Tip**

**Notes**

Table 1&2 shows the recommended recess required to keep the vestige below the part surface.

Consult Synventive when using glass fibers or other fillers.

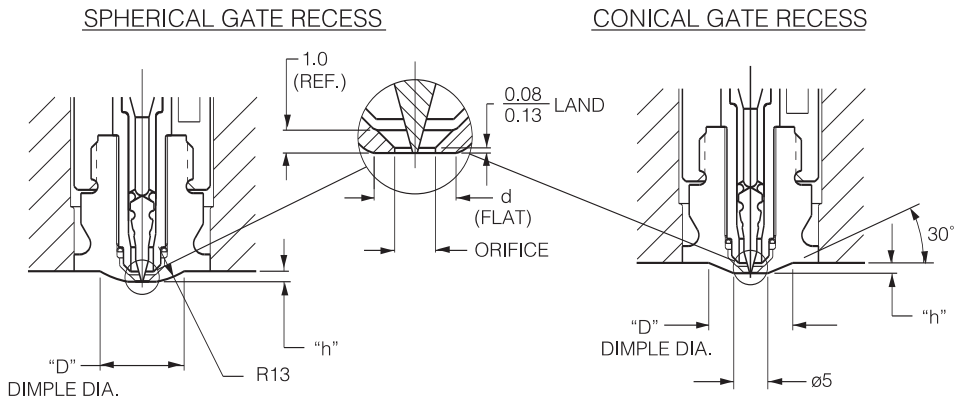

"h" MAX=1.5

ORIFICE DIA.	RECESS h	d	D
0.90-1.00	0.58	1.25	7.78
1.00-1.20	0.66	1.45	8.30
1.20-1.40	0.74	1.65	8.79
1.40-1.60	0.80	1.85	9.16
1.60-1.80	0.86	2.05	9.51
1.80-2.00	0.94	2.25	9.95
2.00-2.20	1.00	2.45	10.27

"D"=5 + 3.5"h"

ORIFICE	RECESS "h"	"D"
.90	.56	7.0
1.00	.59	7.1
1.20	.66	7.3
1.50	.76	7.7
1.80	.86	8.0
2.00	.93	8.3
2.20	.99	8.5

ANGLED MOLD CONTOUR

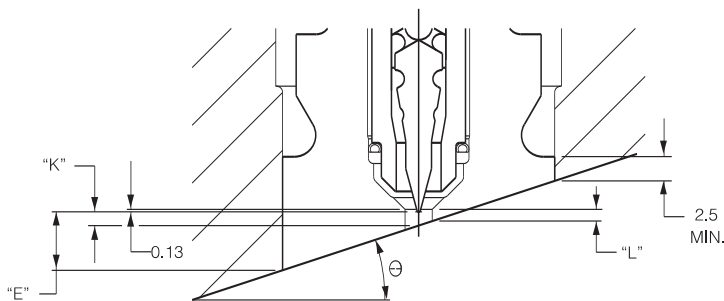

$$\theta \leq 10^\circ ; "K" = \left( \frac{\text{ORIFICE DIA.}}{2} \right) \text{TAN } \theta \quad \theta > 10^\circ ; "K" = \left( \frac{18.1 - \text{ORIFICE DIA.}}{2} \right) \text{TAN } \theta - 1.5$$

$$"E" = \left( \frac{19 + \text{ORIFICE DIA.}}{2} \right) \text{TAN } \theta \quad "E" = K + 9.5 \text{TAN } \theta$$

$$"L" = 0.13 \quad "L" = 0.13 + "K" - \left( \frac{\text{ORIFICE DIA.}}{2} \right) \text{TAN } \theta$$

NOTE:

"K" IS THE INCREASE IN ORIFICE LAND NECESSARY TO MAINTAIN 0.13 LAND AND/OR 2.5 MINIMUM CONTACT.

# GATE MACHINING LIMITS FOR FIELD MODIFICATIONS

**USB5 Hot Sprue Bushing (inches) With CV-20 Tip**

SPHERICAL GATE RECESS

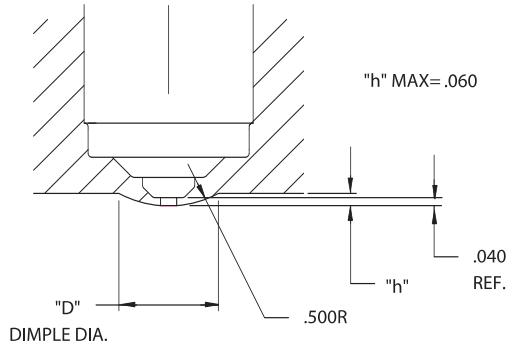

CONICAL GATE RECESS

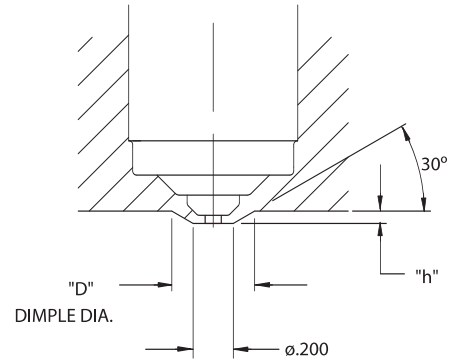

NOTE:  
FOR MOST MATERIALS, CV-20 VESTIGE HEIGHT IS EQUAL TO (.040" + ORIF./2). IF VESTIGE HEIGHT RELATIVE TO THE POSSIBLE GATE RECESS DEPTH IS TOO GREAT, USE OF A CV-21 TIP IS RECOMMENDED TO PRODUCE A SHORTER VESTIGE HEIGHT.

$$"D" = 2\sqrt{"h"(1 - "h")}$$

TABLE 1	
RECESS "h"	"D"
.030	.341
.035	.368
.040	.392
.045	.415
.050	.436
.055	.456
.060	.475

$$"D" = .200 + 3.5"h"$$

TABLE 2	
RECESS "h"	"D"
.030	.305
.035	.323
.040	.340
.045	.358
.050	.375
.055	.393
.060	.410

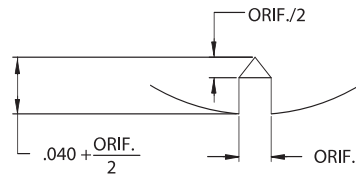

ANGLED MOLD CONTOUR

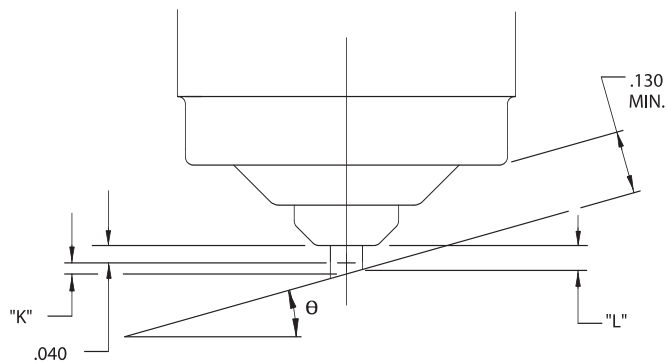

NOTE:

"K" IS THE INCREASE IN ORIFICE LAND NECESSARY TO MAINTAIN .130 MIN. WALL THICKNESS.

$$\theta \leq 15^\circ ; "K" = 0$$

$$"L" = .040 - \left( \frac{\text{ORIFICE DIA.}}{2} \right) \text{TAN } \theta$$

$$\theta > 15^\circ ; "K" = .375 \text{TAN } \theta + \frac{.130}{\text{COS } \theta} - .236$$

$$"L" = .040 + "K" - \left( \frac{\text{ORIFICE DIA.}}{2} \right) \text{TAN } \theta$$

**SB5 Hot Sprue Bushing (metric) With CV-20 Tip**

SPHERICAL GATE RECESS

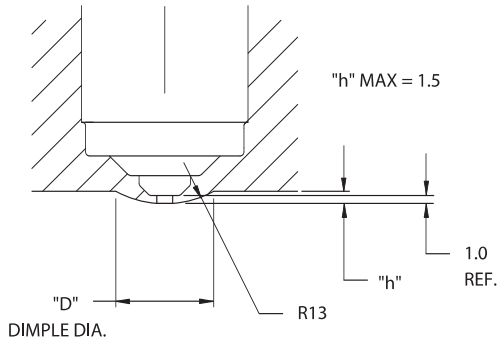

CONICAL GATE RECESS

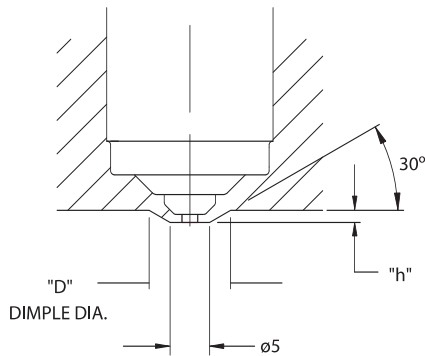

NOTE:  
FOR MOST MATERIALS, CV-20 VESTIGE HEIGHT IS EQUAL TO (1.0mm + ORIF./2).  
IF VESTIGE HEIGHT RELATIVE TO THE POSSIBLE GATE RECESS DEPTH IS TOO GREAT, USE OF A CV-21 TIP IS RECOMMENDED TO PRODUCE A SHORTER VESTIGE HEIGHT.

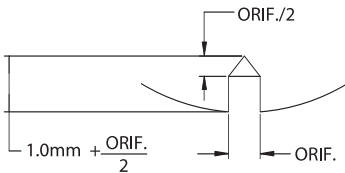

$$"D" = 2\sqrt{"h"(26 - "h")}$$

TABLE 1	
RECESS "h"	"D"
0.6	7.8
0.7	8.4
0.8	9.0
0.9	9.5
1.0	10.0
1.1	10.5
1.2	10.9
1.5	12.1

$$"D" = 5 + 3.5"h"$$

TABLE 2	
RECESS "h"	"D"
0.6	7.1
0.7	7.5
0.8	7.8
0.9	8.2
1.0	8.5
1.1	8.9
1.2	9.2
1.5	10.3

ANGLED MOLD CONTOUR

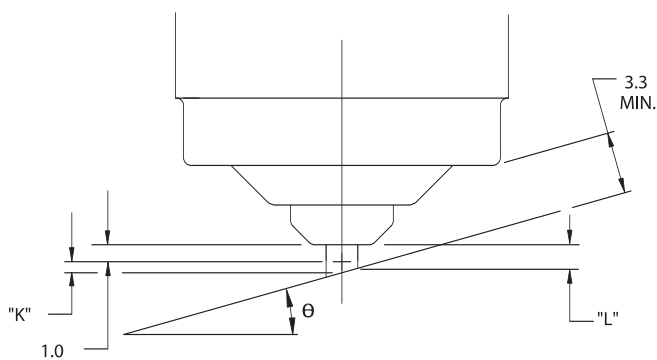

$$\theta \leq 15^\circ ; "K" = 0$$

$$"L" = 1 - \tan \theta \left( \frac{\text{ORIFICE DIA.}}{2} \right)$$

$$\theta > 15^\circ ; "K" = 9.5 \tan \theta + \frac{3.3}{\cos \theta} - 6$$

$$"L" = 1 + "K" - \left( \frac{\text{ORIFICE DIA.}}{2} \right) \tan \theta$$

NOTE:

"K" IS THE INCREASE IN ORIFICE LAND NECESSARY TO MAINTAIN 3.3 MIN. WALL THICKNESS.

# GATE MACHINING LIMITS FOR FIELD MODIFICATIONS

## USB5 Hot Sprue Bushing (inches) With CV-21 Tip

SPHERICAL GATE RECESS

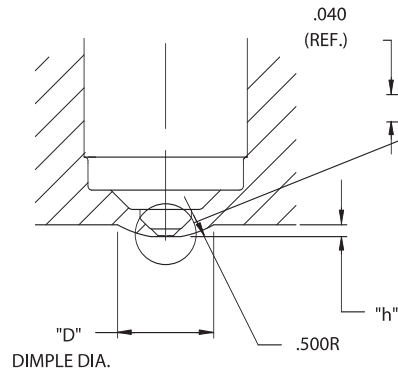

CONICAL GATE RECESS

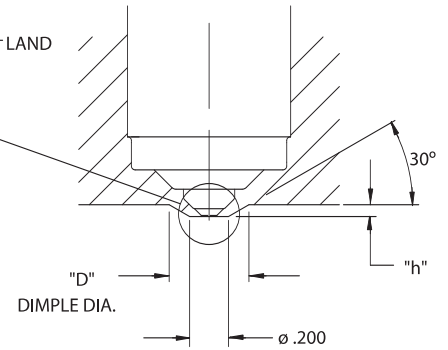

"h" MAX = .060

"D" = .200 + 3.5"h"

NOTE:

TABLE 1&2 SHOWS THE RECOMMENDED RECESS REQUIRED TO KEEP THE VESTIGE BELOW THE PART SURFACE. CONSULT SYNVENTIVE WHEN USING GLASS FIBERS OR OTHER FILLERS.

TABLE 1			
ORIFICE DIA.	RECESS h	d	D
.035-.039	.023	.049	.306
.039-.047	.026	.057	.327
.047-.055	.029	.065	.346
.055-.063	.031	.073	.361
.063-.071	.034	.081	.374
.071-.079	.037	.089	.392
.079-.087	.039	.096	.404

TABLE 2		
ORIFICE	RECESS "h"	"D"
.035	.022	.277
.039	.023	.281
.047	.026	.291
.059	.030	.305
.071	.034	.319
.079	.037	.330
.087	.039	.337

ANGLED MOLD CONTOUR

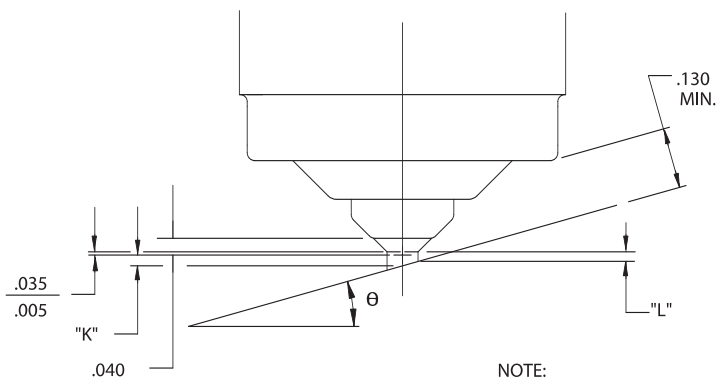

NOTE:

"K" IS THE INCREASE IN ORIFICE LAND NECESSARY TO MAINTAIN .005 LAND AND/OR .130 MINIMUM WALL THICKNESS.

$$\theta \leq 15^\circ ; "K" = \left( \frac{\text{ORIFICE DIA.}}{2} \right) \text{TAN } \theta$$

$$"L" = .005$$

$$\theta > 15^\circ ; "K" = .375 \text{TAN } \theta + \frac{.130}{\text{COS } \theta} + \left( \frac{\text{ORIFICE DIA.} - .035}{2} \right) \text{TAN } \theta - .236$$

$$"L" = .005 + "K" - \left( \frac{\text{ORIFICE DIA.}}{2} \right) \text{TAN } \theta$$

**SB5 Hot Sprue Bushing (metric) With CV-21 Tip**

SPHERICAL GATE RECESS

CONICAL GATE RECESS

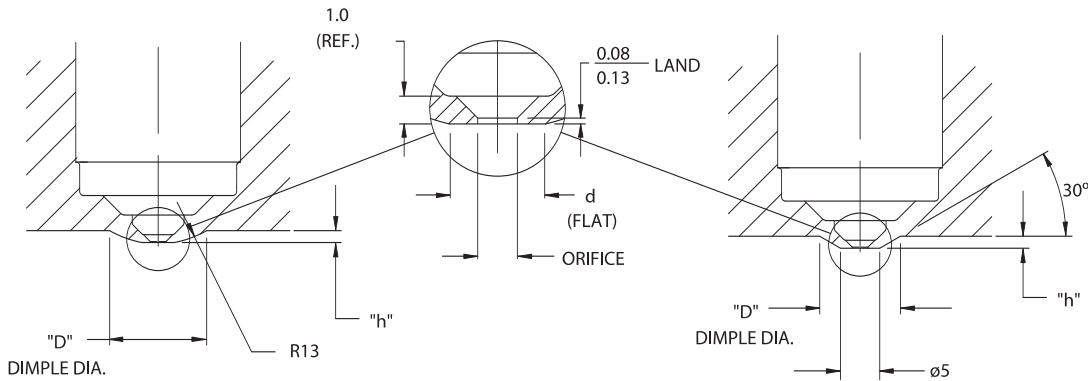

"h" MAX = 1.5

TABLE 1			
ORIFICE DIA.	RECESS h	d	D
0.90 – 1.00	0.58	1.25	7.78
1.00 – 1.20	0.66	1.45	8.30
1.20 – 1.40	0.74	1.65	8.79
1.40 – 1.60	0.80	1.85	9.16
1.60 – 1.80	0.86	2.05	9.51
1.80 – 2.00	0.94	2.25	9.95
2.00 – 2.20	1.00	2.45	10.27

"D" = 5 + 3.5"h"

TABLE 2		
ORIFICE	RECESS "h"	"D"
0.90	0.56	7.0
1.00	0.59	7.1
1.20	0.66	7.3
1.50	0.76	7.7
1.80	0.86	8.0
2.00	0.93	8.3
2.20	0.99	8.5

ANGLED MOLD CONTOUR

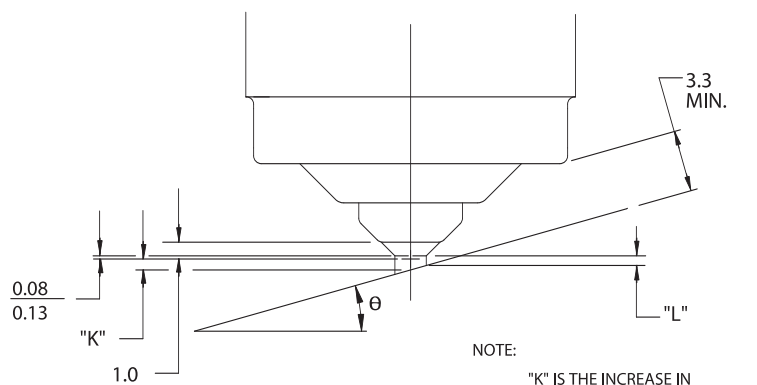

NOTE:

"K" IS THE INCREASE IN ORIFICE LAND NECESSARY TO MAINTAIN 0.13 LAND AND/OR 3.3 MINIMUM WALL THICKNESS.

$$\theta \leq 15^\circ ; "K" = \left( \frac{\text{ORIFICE DIA.}}{2} \right) \text{TAN } \theta$$

$$"L" = .13$$

$$\theta > 15^\circ ; "K" = 9.5 \text{TAN } \theta + \frac{3.3}{\text{COS } \theta} + \left( \frac{\text{ORIFICE DIA.} - .9}{2} \right) \text{TAN } \theta - 6$$

$$"L" = .13 + "K" - \left( \frac{\text{ORIFICE DIA.}}{2} \right) \text{TAN } \theta$$

**Notes**

Table 1&2 shows the recommended recess required to keep the vestige below the part surface.

Consult Synventive when using glass fibers or other fillers.

# ORIFICE DIAMETER GUIDELINES

This table lists the normal gate orifice required to fill an average cavity of the listed wall thickness and surface area.

Part Area inch <sup>2</sup> /(mm <sup>2</sup> )*	WALL THICKNESS inch/(mm)									
	.030 (.75)	.040 (1.0)	.050 (1.25)	.060 (1.50)	.070 (1.75)	.080 (2.0)	.090 (2.25)	.100 (2.50)	.125 (3.0)	.156 (4.0)
1.0 (600)	.035 (0.90)	.035 (0.90)	.035 (0.90)	.035 (0.90)	.035 (0.90)	.035 (0.90)	.037 (0.95)	.039 (2.00)	.044 (1.12)	.050 (1.27)
2.0 (1200)	.035 (0.90)	.035 (0.90)	.035 (0.90)	.036 (0.92)	.039 (1.00)	.041 (1.05)	.044 (1.12)	.046 (1.17)	.052 (1.32)	.059 (1.50)
3.0 (1800)	.035 (0.90)	.035 (0.90)	.037 (0.95)	.040 (1.02)	.043 (1.10)	.046 (1.17)	.049 (1.25)	.051 (1.30)	.058 (1.47)	.066 (1.68)
4.0 (2400)	.035 (0.90)	.035 (0.90)	.040 (1.02)	.043 (1.10)	.047 (1.20)	.049 (1.25)	.053 (1.35)	.055 (1.40)	.062 (1.58)	.070 (1.78)
5.0 (3000)	.035 (0.90)	.037 (0.95)	.042 (1.07)	.046 (1.17)	.049 (1.25)	.052 (1.32)	.056 (1.42)	.058 (1.47)	.065 (1.65)	.074 (1.88)
10.0 (6000)	.038 (1.00)	.044 (1.12)	.050 (1.27)	.054 (1.37)	.059 (1.50)	.062 (1.58)	.066 (1.68)	.069 (1.76)	.078 (1.98)	.089 (2.26)
20.0 (12,000)	.046 (1.17)	.052 (1.32)	.060 (1.53)	.065 (1.65)	.070 (1.78)	.074 (1.88)	.079 (2.00)	.082 (2.08)	.093 (2.36)	.105 (2.67)
30.0 (18,000)	.051 (1.30)	.058 (1.47)	.066 (1.68)	.072 (1.83)	.077 (1.96)	.081 (2.06)	.087 (2.21)	.091 (2.31)	.103 (2.62)	.117 (2.97)
40.0 (24,000)	.054 (1.37)	.062 (1.58)	.071 (1.80)	.077 (1.96)	.083 (2.10)	.088 (2.24)	.094 (2.39)	.098 (2.49)	.110 (2.80)	.125 (3.18)
50.0 (30,000)	.057 (1.45)	.065 (1.65)	.075 (1.90)	.081 (2.06)	.088 (2.24)	.093 (2.36)	.099 (2.51)	.104 (2.64)	.116 (2.95)	.132 (3.35)
60.0 (36,000)	.060 (1.53)	.068 (1.73)	.078 (1.98)	.085 (2.16)	.092 (2.34)	.097 (2.46)	.104 (2.64)	.109 (2.77)	.122 (3.10)	.139 (3.53)
70.0 (42,000)	.062 (1.58)	.071 (1.80)	.082 (2.08)	.089 (2.26)	.095 (2.41)	.101 (2.57)	.108 (2.75)	.113 (2.87)	.127 (3.23)	.144 (3.66)
80.0 (48,000)	.065 (1.65)	.074 (1.88)	.084 (2.13)	.092 (2.34)	.099 (2.51)	.104 (2.64)	.111 (2.82)	.117 (2.97)	.131 (3.33)	.149 (3.79)
90.0 (54,000)	.067 (1.70)	.076 (1.93)	.087 (2.21)	.094 (2.39)	.102 (2.60)	.107 (2.72)	.115 (2.92)	.120 (3.05)	.135 (3.43)	.153 (3.89)
100.0 (60,000)	.068 (1.73)	.078 (1.98)	.089 (2.26)	.097 (2.46)	.104 (2.64)	.110 (2.80)	.118 (3.00)	.123 (3.12)	.139 (3.53)	.157 (3.99)
150.0 (90,000)	.076 (1.93)	.086 (2.18)	.099 (2.51)	.107 (2.72)	.115 (2.92)	.122 (3.10)	.130 (3.30)	.136 (3.45)	.153 (3.89)	.174 (4.42)
200.0 (120,000)	-	.093 (2.36)	.106 (2.70)	.115 (2.92)	.124 (3.1)	.131 (3.33)	.140 (3.56)	.147 (3.73)	.165 (4.20)	.187 (4.75)
300.0 (180,000)	-	-	.117 (2.97)	.127 (3.23)	.137 (3.48)	.145 (3.68)	.155 (3.94)	.162 (4.15)	.182 (4.62)	.207 (5.26)
400.0 (240,000)	-	-	-	.137 (3.48)	.148 (3.76)	.156 (3.98)	.166 (4.22)	.174 (4.42)	.196 (4.98)	.218 (5.54)

\* Part area is total outside surface area not projected area (i.e. includes side walls, etc.).

1. Material Factors:

- Use Tabulated Orifice for PE, PP, PS, SAN, PUR
- Use Tabulated Orifice x 1.15 for Acetal, PC, PPO, ABS
- Use Tabulated Orifice x 1.30 for Acrylic, Nylon, PET, PBT (see note 5)
- Use Tabulated Orifice x 1.50 for PVC

2. This diameter is based on the flow and freeze characteristics of each type of plastic at its normal processing conditions. It is not dependent on the type of nozzle or whether it is fed by a hot or cold runner system.

- Hot Runner Gates: CV-10, CV-11, CV-11S, CV-20, CV-21, CV-21S, EG-10
- Cold Runner Gates: Pin, Sub-Gate, Edge-Gate

This diameter size applies to most gate styles.

3. Some of the listed wall thickness and surface area combinations are not applicable to all plastics because of flow-length-to-wall ratios of each plastic – consult plastic supplier's processing recommendations (e.g. 400 inch<sup>2</sup> surface area of .060 (1.50 mm) wall is possible for some cavities with PE, but is not possible with most other plastics).

4. The gate diameter limitations – minimum and maximum – which apply to each Synventive hot runner nozzle may require the actual gate to be slightly smaller or larger than the tabulated orifice.

5. Due to the crystalline nature of Nylon, PET and PBT, the minimum orifice for non-reinforced grades should be .094 (2.39 mm) and for reinforced grades .156 (3.96 mm).

6. For filled crystalline materials, nylon, PET and PBT when using full flow inserts, the gate orifice should be 1mm smaller than the insert orifice.

These products may be covered by some or all of the following patents:  
 US 6464909, US 6436320, US 6419840, US 6361300, US 6343921, US 6343922, US 6309208, US 6294122, US 6287107,  
 US 6261084, US 6261075, US 6254377, US 6062840, US 5980237, US 5948448, US 5948450, US 5916605, US 5894025,  
 US 5885628, US 5871786, US 5674439, US 5556582, US 5554395, US 5545028, US 5492467



## Material Compatibility

MATERIAL	Synventive Hot Sprue Bushings			
	USB5*, SB5*, USB8, SB8, SB13, SB15 & SB24**			
	Synventive Tip Styles			
	CV-10	CV-11	CV-20	CV-21
ABS	1	1	1	1
ABS GR ***	1	2	1	2
ACETAL (POM)	NR	1	NR	1
ACETAL GR	1	2	1	2
ACRYLIC	1	1	1	1
LCP	NR	1	NR	1
PPO	1	1	1	1
NYLON 6 ***	NR	1	NR	1
NYLON 6 GR ***	1	2	1	2
NYLON 66 ***	NR	1	NR	1
NYLON 66 GR ***	1	2	1	2
NYLON 66 (MINERAL FILLED) ***	NR	1	NR	1
POLYCARBONATE ***	1	1	1	1
POLYCARBONATE GR	1	2	1	2
PC/ABS BLEND	1	1	1	1
PC/POLYESTER BLEND	1	1	1	1
POLYESTER (PBT) ***	NR	1	NR	1
POLYESTER (PBT) GR ***	1	2	1	2
POLYESTER (PET) BOTTLE GRADE	1	1	1	1
POLYESTER (PET) GR ***	1	2	1	2
POLYETHYLENE	1	1	1	1
POLYPROPYLENE	1	1	1	1
POLYSTYRENE	1	1	1	1
STYRENE-ACRYLONITRILE (SAN)	1	1	1	1
STYRENE BUTADIENE	1	1	1	1
STYRENE MALEIC ANHYDRIDE (SMA)	1	1	1	1
SMA (GR)	1	2	1	2
POLYURETHANE	1	1	1	1
PVC RIGID ***	1	2	1	2
PVC FLEXIBLE ***	2	1	2	1
TPE	NR	1	NR	1
TPR	NR	1	NR	1
TPO	1	1	1	1

## Notes

GR-Glass Reinforced

NR-Not Recommended for

Most Applications

Recommended Tip/Bushing

1. Most Suitable

2. Suitable with some

reservations:

e.g. Gate Control, etc.

(Not as good as category 1)

See page 24 for correct

Orifice Sizing

\* USB5 & SB5 Bushings

are NR-For Glass

Filled Materials.

\*\* SB24 Bushings are

available with CV-10 &

CV-20 tips only.

\*\*\* See Orifice Diameter

Requirements, page 24.

# CONTROLLED VESTIGE (CV) TIPS

## CV-10 Full-Flow

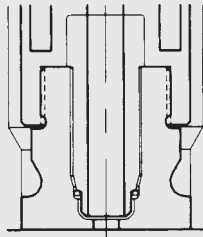

- This is the most widely used tip.
- Vestige height is equal to orifice diameter.
- Provides best gate control for most materials.
- Open flow bore provides low pressure drop.
- Tramp metal can usually flow through tip.
- Orifice is increased by simple straight reaming of diameter.

## CV-11 Cone

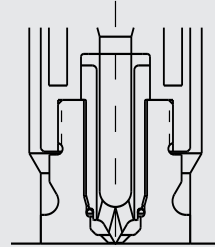

- This tip style is used primarily to provide reduced vestige height, 0.4- 0.9mm high for all materials.
- Cone Point adds heat to center of orifice for nylon, acetal and PBT.
- Orifice adjustment requires added machining to hold land length at 0.08/0.13mm.

## CV-20 Full-Flow

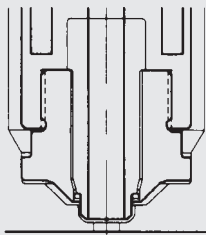

- Same as CV-10 except gate orifice is machined into mold plate to eliminate circular witness mark of tip.
- For use in gating into runner or directly onto part surface.

## CV-21 Cone

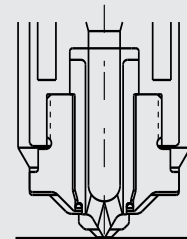

- Same as CV-11 except gate orifice is machined into mold plate to eliminate circular witness mark of tip.
- For use in gating into runner or directly onto part surface.

# ACCESSORIES

## REPLACEMENT BAND HEATERS

DESCRIPTION	PART NO.
<b>USB5/SB5 and USB8/SB8</b>	
45mm (1.75") I.D. x 35mm (1.38") wide, 450 Watts, 120 Volts	81-16-105
240 Volts	81-16-107
<b>SB13</b>	
50mm I.D. x 50mm wide, 750 Watts, 120 Volts	81-20-114
240 Volts	81-20-116
<b>SB15</b>	
44.5mm I.D. x 50mm wide, 750 Watts, 120 Volts	81-16-112
240 Volts	81-16-113
<b>SB24B</b>	
57mm I.D. x 64mm wide, 1000 Watts, 120 Volts	81-22-124
240 Volts	81-22-125

## REPLACEMENT THERMOCOUPLES

DESCRIPTION	PART NO.
T°C for USB5, SB5, USB8, SB8, SB13	83-192-048
T°C for SB15, SB24	83-187-120

## TEMPERATURE CONTROLLERS

Single Zone 15 Amp Temperature Controller includes one thermocouple connector (80-M2MJ)

Catalog Number	Amp/Voltage	Input connector Catalog No.*	Output connector Catalog No.*
80-PIM1A15	15A/240V	80-AC1524F (NEMA 6-15)	80-AC1524M (NEMA 6-15)
80-PIM1A151	15A/120V	80-AC1512F (NEMA 5-15)	80-AC1512M (NEMA 5-15)

Synventive offers a complete line of single and multi-zone temperature control systems. For details, see Temperature Control Systems Design Manual.

# USB5 AND SB5 TIP REMOVAL/REPLACEMENT

## Tip Removal

1. Slip each half of split wrench onto flats of tip. Slide 27mm 6 point deep socket wrench over split wrench. Torque off tip with wrench assembly. See Figure 1.
2. Tips are usually removed at room temperature. If tip does not break free, heat bushing to operating melt temperature.

## Insert Removal

1. The conductive BeCu insert should only be removed if it is to be replaced by a new insert. Reinstallation of the same insert may affect the heat transfer from the steel body to the BeCu insert.
2. Using a 4.3mm dia. drill, machine into the center of the insert for a depth of 10mm, and then thread using a M5 tap.
3. After the insert is tapped, thread in a M5 rod. Place the insert removal tool (Figure 3) over the rod. Using a M5 nut, thread the nut against the removal tool to pull out the insert. See Figure 2.

## Tip Replacement

1. Clean any and all plastic from SYNVENTIVE-SEAL and from the inside sealing diameter on tip. Care must be taken not to damage SYNVENTIVE-SEAL.
2. Verify seating between tip and body by the application of blueing to tip seat.
3. Verify that the SYNVENTIVE-SEAL is in place prior to tip installation.
4. Torque tip to the recommended torque of 6.9 kg.M (50 ft.lb) for all tip styles (see tip removal for wrenching information).

## Insert Replacement

1. Clean any and all plastic from the insert counter bore, measure the insert counter bore diameter and insert press diameter.
2. The diameter of the insert should be .013-.030mm larger than the diameter of the mating counter bore in the steel body. This is necessary to assure proper heat transfer to the BeCu insert.
3. The insert must be pressed so that the insert shoulder is flush with the tip seat  $\pm .013$ mm (Figure 4). This is achieved by using the insert installation tool as shown in Figure 5. Use a small arbor press.

## SYNVENTIVE-SEAL Replacement

Always inspect the SYNVENTIVE-SEAL when replacing a tip. No plastic should have leaked past the seal, nor should there be scratches or dents in the seal O.D. Thermal operation of the gate will be affected by any damage or plastic leakage.

Remove a damaged SYNVENTIVE-SEAL by using a removal tool to avoid scratching the insert sealing diameter. Replace the SYNVENTIVE-SEAL only onto an insert sealing diameter that is smooth and free of plastic. Use a light arbor press and pressing tool to bottom the SYNVENTIVE-SEAL on the insert shoulder. Do not overpress.

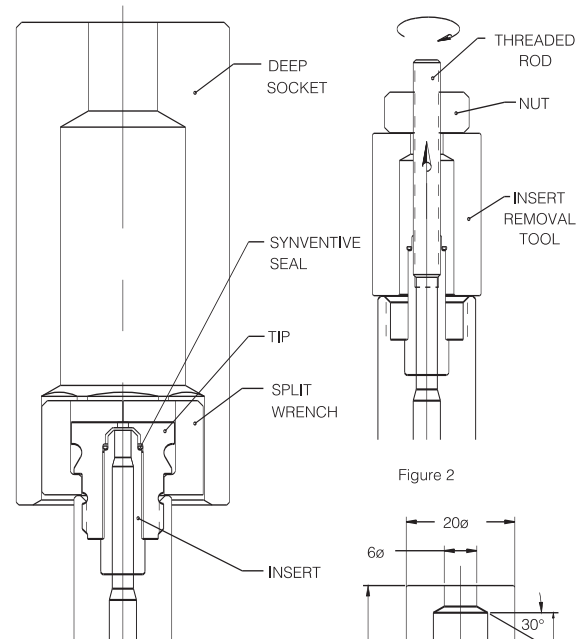

Figure 1

Figure 2

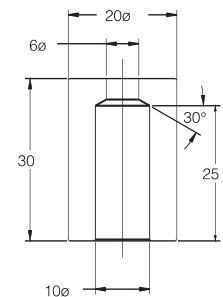

Figure 3

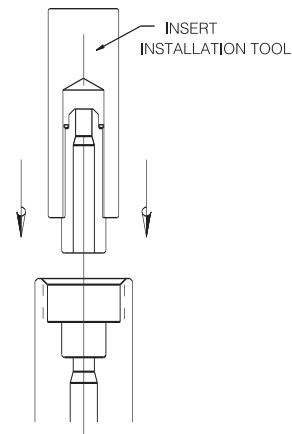
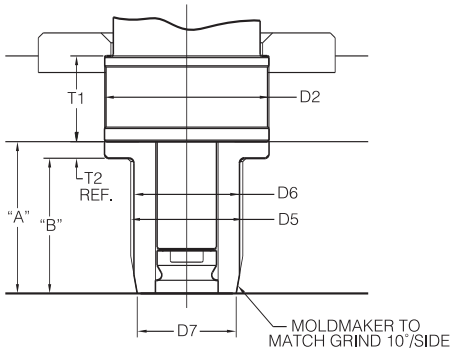

Figure 4

Figure 5

## For USB5 And SB5 Bushing



	SB5	USB5
T1	26.0	.875
T2	5.0	.187
D2	50.0	2.000
D5	32.0	1.250
D6	34.0	1.350
D7	30.0	1.187

MODEL #	A	B
USB5-0020	0.875	.688
USB5-1010	1.375	1.188
USB5-1020	1.875	1.688
USB5-2010	2.375	2.188
USB5-2020	2.875	2.688
USB5-3010	3.375	3.188
USB5-3020	3.875	3.688
USB5-4010	4.375	4.188

MODEL #	A	B
SB5-022	22.0	17.0
SB5-027	27.0	22.0
SB5-036	36.0	31.0
SB5-046	46.0	41.0
SB5-056	56.0	51.0
SB5-066	66.0	61.0
SB5-076	76.0	71.0
SB5-086	86.0	81.0
SB5-096	96.0	91.0
SB5-106	106.0	101.0

## For USB8 And SB8 Bushing

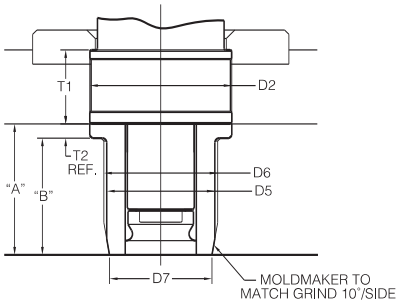

	SB8	USB8
T1	26.0	.875
T2	5.0	.187
D2	50.0	2.000
D5	38.0	1.500
D6	40.0	1.575
D7	36.0	1.420

MODEL #	A	B
USB8-1010	1.375	1.188
USB8-1020	1.875	1.688
USB8-2010	2.375	2.188
USB8-2020	2.875	2.688
USB8-3010	3.375	3.188
USB8-3020	3.875	3.688
USB8-4010	4.375	4.188
USB8-4020	4.875	4.688

MODEL #	A	B
SB8-027	27.0	22.0
SB8-036	36.0	31.0
SB8-046	46.0	41.0
SB8-056	56.0	51.0
SB8-066	66.0	61.0
SB8-076	76.0	71.0
SB8-086	86.0	81.0
SB8-096	96.0	91.0
SB8-106	106.0	101.0
SB8-116	116.0	111.0

## For SB13 Bushing

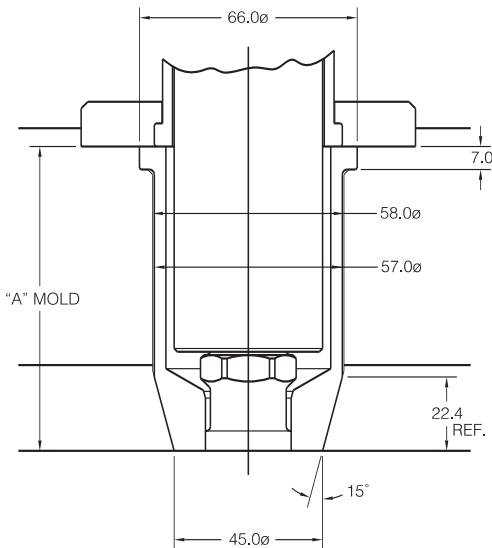

NOTE  
 DUE TO NON-STANDARD CUSTOM  
 "A" LENGTHS FOUND ON SB13 BUSHINGS  
 THE MOLD MAKER MUST DESIGN AND  
 MANUFACTURE A CUSTOM STRIPPER  
 SLEEVE. THE FOLLOWING INFORMATION  
 IS PROVIDED TO HELP DESIGN THE  
 PROPER STRIPPER SLEEVE